

108 H/HP Operational Manual





Assembly & Operations Manual

Home Model VersaClimber CL-108H & CL-108HP

ph:714.850.9716 • 800.237.2271 • fx: 714.755.5749

3190-E Airport Loop, Costa Mesa CA 92626 • versaclimber.com • email@heartrateinc.com

VersaClimber is proudly manufactured in USA by Heart Rate Inc. All Rights Reserved 2003.



Table Of Contents

	<u>Page</u>
Introduction.....	1
Exercise Tips.....	3
Exercise Guidelines	4
VersaClimber Specifications.....	7
Display Module CL-108 H.....	8
User's Guide.....	9
Standard Mode.....	9
Program Mode.....	12-14
Race Mode.....	15-17
Program Level Chart.....	18
Display Module CL-108 HP (<i>Heart Rate Control</i>).....	19
Heart Rate Monitoring Instructions.....	20-22
Oxygen Consumption.....	23
Training Heart Rates.....	23
Calorie Burn Rate Chart.....	24
Strength Exercises.....	25
Working The Upper & Lower Body Separately.....	25-27
Interval Training.....	28
VersaClimbing and Children.....	29
VersaClimbing for Adults.....	29
VersaClimbing and The Overweight Person.....	30
Top These Towers!.....	31
VersaClimber Assembly Instructions.....	32-37
Routine Maintenance.....	38-39
Lubrication.....	40
VersaClimber Assembly Sketches.....	41-43
Warranty Parts.....	44-46
Warranty Validation Form.....	47

————— Introduction —————

Congratulations on the purchase of your new VersaClimber--the original total body climber! The VersaClimber provides a more complete, safe and overall better exercise than treadmills, ellipticals, steppers, running, cycling, swimming, rowing or cross country skiing because the VersaClimber works all the major muscles of the body in one safe, smooth rhythmic motion.

Climbing against gravity also burns more calories than any other exercise. VersaClimber accommodates all levels of fitness and ages because you can walk, jog, run, or sprint vertically at various stride lengths and running speeds.

With a simple positioning of the hands (holding on the side rails), your VersaClimber becomes a stepping machine to concentrate the work on the lower body. By having a stair stepper and climber all in one machine, you can change your workouts easily to keep you motivated and exercising toward your fitness goals.

The following pages will offer some guidelines to gain an understanding of the functions and multiple uses of the VersaClimber. These guidelines are not specific individual exercise prescriptions, but rather, general VersaClimber user information.

Most functions and their operation are applicable to both CL-108H and CL-108HP Model VersaClimbers. Throughout this manual, references and instructions have been included for the CL-108HP VersaClimber model with Heart Rate Control.

WARNING:

READ ALL INSTRUCTIONS CAREFULLY

**Before assembling or exercising on the VersaClimber,
READ THIS ASSEMBLY AND OPERATION MANUAL THOROUGHLY.
Instruct others how to use the machine in accordance with
procedure outlined in this manual.**

Consult your physician before beginning this or any other exercise program. This is especially important for individuals over the age of 30 and those that have known health problems. *HEART RATE INC., IS NOT RESPONSIBLE FOR PERSONAL INJURY OR PROPERTY DAMAGE SUSTAINED BY OR THROUGH THE USE OF THE VERSACLIMBER.*

Because of the very low perception of exertion while climbing, the first time user has a tendency to climb too fast and take too long of a stroke (step). Until you become thoroughly familiar with the VersaClimber, it is suggested that the user take short, slow steps (4-6 inches). Increase the step rate and step length only after you become familiar with this total body climbing and stepping exercise.

DO NOT OVER EXERT YOURSELF! IMMEDIATELY DISCONTINUE THIS OR ANY OTHER EXERCISE IF YOU FEEL FAINT, DIZZY, SHORTNESS OF BREATH OR ANY OTHER PHYSICAL DISCOMFORT.

Specific user questions should be directed to:

**Heart Rate Inc.
3190-E Airport Loop
Costa Mesa, CA 92626
800.237.2271**

versaclimber.com • email@heartrateinc.com

EXERCISE TIPS

- 1.** Consult your physician before starting this or any other exercise program especially if health problems are known.
- 2.** While exercising, the foot pedals and hand grips are moving up and down. *DO NOT ALLOW YOUNG CHILDREN OR ANYONE TO BE WITHIN 3 FEET OF ANY PART OF THE MACHINE WHILE IT IS IN USE.*
- 3.** Beginners may want to stair step before doing a full body climbing exercise. Please visit section “*Working the upper and lower body separately*” page 25.
- 4.** Be sure that your clothing is comfortable and loose fitting so that your range of motion is not restricted. Loose clothing may get caught in the machine. A comfortable pair of running shoes is also recommended.
- 5.** Always maintain a good upright posture (back straight, buttocks in, chest out, stomach in).
- 6.** Climbing can cause you to sweat profusely which is a normal, healthy reaction to exercise. To avoid dehydration, it is important to maintain/replace body fluids before, during and after exercising.
- 7.** To lose weight, eat sensibly while maintaining a regular VersaClimbing schedule. Decrease your calorie intake by avoiding fatty foods and sweets in your diet.
- 8.** Exercising in hot humid weather may be hazardous to your health. During these days, plan to exercise in the early morning or early evening when it is cooler.
- 9.** By keeping a log of your workout, you can set goals for yourself and your family, watch your progression and set new goals accordingly. The following is an example exercise log you may use.

VERSACLIMBER EXERCISE LOG

Name (lbs)	Weight Minute	Feet Per Minute	Exercise Time	Total Feet	Total Calories Burned	Comments
<i>Bob</i>	<i>190</i>	<i>115</i>	<i>30 min</i>	<i>3,450</i>	<i>425</i>	<i>Drink more water</i>

- 10.** Always include a warm up and cool down period in your workouts. If you have selected a PROGRAM MODE or HEART RATE CONTROL MODE, your warm up will be included in your program. The gradual increase in the intensity of your PROGRAMMED workout is based on feet per minute. The HEART RATE

CONTROL mode of the CL-108HP VersaClimber will guide you through a workout which slowly increases in intensity until you reach and maintain a specific heart rate. A 5 minute cool down period is recommended in all modes, gradually decreasing your climb rate and/or lowering the arms by grasping the hand rails. Cool down should be continued until your heart and breathing rate has been lowered to a near resting heart rate.

————— **EXERCISE GUIDELINES** —————

WARM UP

A proper warm up, before beginning any exercise, will greatly reduce the risk of injury and increase performance. Stretching the muscles and tendons is often thought of as “not needed” or “waste of time” but that is not true. Not only is the range of motion of the joints increased, but also the body temperature and the amount of oxygenated blood circulated to active muscles is increased. If the muscles have more oxygen, they can perform better. A ten to fifteen minute warm up is recommended using a variety of slow stretches. To continue your warm up you may want to hold the handrails of the VersaClimber and try stair stepping. By holding the hand rails take short chopping steps no more than 4-6 inches at a rate that is easy and comfortable.

CHOOSING YOUR EXERCISE AND TARGET HEART RATE

Exercise guidelines include the type, intensity, duration, frequency and progression of physical activity. These five components need to be considered before you begin your exercise program on the VersaClimber.

TYPE OF EXERCISE CLIMBING

The VersaClimber is a full body, smooth, non-impact climbing exercise that uses most of the major muscles in the body. The VersaClimb exercise incorporates one of the most natural activities to which the body can be subjected—vertical climbing. The VersaClimber incorporates a push/pull motion with the right arm and right leg approaching each other, while the left arm and left leg separate. As the motion alternates, a simulated vertical running motion is reproduced. Vertical running exercises the muscles in the arms, chest, shoulders and back of the upper body in addition to the lower body.

STEPPING

The hand rails transfer the lower half of the total body machine into a stepper. Stepping concentrates the work on the lower body; the glutes, quadriceps, hamstrings, shins, and calves. Without any machine adjustments, the user can change exercises from stepping to climbing by moving the hands from the rails to the moving hand grips. The VersaClimber utilizes four fundamental exercise modalities: **Aerobic** and **Anaerobic** training for cardiorespiratory improvements. **Strength** and muscular **Endurance** for dynamic health.

INTENSITY

Based on the general population, the intensity of your workout should be maintained at 70% to 85% of your maximum heart rate unless advised otherwise by your doctor. To determine your target refer to the HEART RATE TRAINING ZONE chart on page 23.

To calculate your target heart rate take $220 - \text{Age} \times 70\%$ to $85\% = \text{Target Heart Rate}$. This value may be changed to within 20 beats of the computers calculated value. After a maximal heart rate has been entered, the computer will calculate and display your target heart rate value (80% of the maximum heart rate). Refer to Heart Rate Monitoring Instructions page 20 -23. It is always important for beginners to exercise at very low levels and to warm up and cool down no matter at what intensity you begin.

Heart Rate Training Values For Healthy 45 Year Old:

$220 - 45 = 175 \times 60\% = 105$ (Beginner Target Heart Rate)

$220 - 45 = 175 \times 70\% = 123$ (Intermediate Target Heart Rate)

$220 - 45 = 175 \times 85\% = 149$ (Advanced Target Heart Rate)

If perceived exercise is used to establish a work intensity:

–A beginner may want to begin at an intensity which is approximately equal to a brisk walk.

–An intermediate may want to begin at an intensity which is approximately equal to a jog.

–An advanced athlete may want to begin at an intensity that is approximately equal to a run.

The CL-108H VersaClimber model does not have internal heart rate monitoring system like the CL-108HP models. However, heart rate may be taken manually at any time before, during and after your workouts by referring to the next section.

TAKING YOUR HEART RATE (MANUAL METHOD)

To take your pulse or heart rate, place two fingers (not thumb) under jaw bone to the right or left side of the throat. Count the number of beats for 15 seconds and multiply that number by 4. This number will give your heart rate in beats per minute. You should check your heart rate periodically during your workout and maintain it in your target heart rate zone. **See Target Heart Rates Page 23.** Adjust the intensity of your workout by increasing or decreasing your rate of climb (feet per minute and step height) accordingly.

DURATION

The duration of the workout depends on your level of conditioning and the intensity of the workout. Normally 15 to 30 minutes continuous climbing or stepping is average, which includes 5 - 10 minutes of warm up and 5 - 10 minutes of cool down. These periods should be at a comfortable easy pace. As you become an advanced or elite climber, the duration of your workout can increase to an hour or more.

FREQUENCY

The frequency of your workout should be 3 to 5 exercise sessions per week, depending on the capacity of the individual. It may be beneficial to alternate a day of climbing with a day of rest until you fully adapt to the exercise.

RATE OF PROGRESSION

The rate of progression is determined by the intensity and the duration of your exercise program. The user should be fully adapted to and comfortable with their workout level before increasing the intensity and duration. While some people may be considered to be in "good condition" because they are already engaging in an exercise program, it is recommended that the user climb for at least 3 weeks before progressing to the next level. As a general rule, adaptation to conditioning takes an additional week for each 10 years of age after the age of 30.

***THOSE INDIVIDUALS WHO HAVE ANY HEALTH PROBLEMS MUST
HAVE THEIR EXERCISE PROGRAMS MODIFIED AND MONITORED
BY THEIR PHYSICIAN.***

As a general rule, a 5% increase in training heart rate every 4-6 weeks is recommended. Increase your training heart rate until 85% of your maximal heart rate is achieved. The "maintenance" stage of exercise prescription usually begins after the 6 to 9 months of training. During this "maintenance" stage, the user reaches a plateau of cardiovascular conditioning and maintains the same workout schedule and level of fitness until a new goal is considered.

— SPECIFICATIONS —

PHYSICAL CHARACTERISTICS

	CL-108H	CL-108HP
Height	7 Feet 6 Inches (90 inches)	SAME
Required Floor Space	36 Inches x 44 Inches	SAME
Weight	63 pounds	SAME
Structural	Aluminum and Steel	SAME
Sliding and Rollings Bearings	Lubricant Filled Nylon	SAME
Date Processing	8bit microcomputer	SAME
Data Display	22digit LCD	SAME
Battery Powered	Module/9volt	SAME
Moving Hand Grips	2	SAME
Stationary Handrails	2	SAME
Hand Grip Adjustment	4.5 increments	SAME
Foot Pedals	2 Aluminum, 5inches x 6 inches	SAME
Foot Pedal Straps	Velcro	SAME
Foot Pedal Adjustments	3.25 inches	SAME
Leveling Adjustments	3	SAME

FUNCTIONAL FEATURES

Climb Angle	75 degrees	SAME
Vertical Lift Factor	96.6 percent	SAME
Climb Rate	0 feet to Unlimited	SAME
Step Height/Stroke Length	0 to 20 inches	SAME
Body Motion	Arms and Legs, Legs, Arms	SAME
Minimum Height to Climb	3ft. 6 inches and taller	SAME
Climber's Weight	70-300lbs.	SAME
Age and Sex	Any	SAME
Level of Fitness	Beginner to Elite Athlete	SAME

MODULE FUNCTIONS

Switch	On or Off	SAME
Battery Saver	Turns off in 2 minutes	SAME
Exercise Time	0 to 99:99 minutes:seconds	SAME
Calories Burn Rate	0 to 3000 per hour	SAME
Display Total Calories	0 to 9999 calories	SAME
Range, Heart Rate Control	N/A	Max 220 MIN 30
Exercise Rate	0 to Unlimited feet per minute	SAME
Program Levels	1 to 16	SAME
Total Vertical Feet Climbed	0 to 9999 feet	SAME
Opponent's Total Vertical Feet Climbed	0 to 9999	SAME
Step Height/Stroke Length	0 to 20 inches	SAME
Instant Replay	N/A	Heart Rate and Feet per Minute at one minute intervals

*Specifications may change without prior notice at the sole discretion of the manufacturer.

Display Module CL-108 H



USER GUIDE

The display module provides three modes of operation:

STANDARD, PROGRAM, RACE

(The CL-108HP Model provides an additional mode: **HEART RATE CONTROL**)

A) STANDARD MODE displays exercise time, calorie burn rate, climbing speed, total distance climbed, and step stroke length.

B) PROGRAM MODE allows the selection of one of 16 pre-programmed workout routines.

C) RACE MODE provides the ability race against an imaginary computer opponent for a selected distance and time.

D) HEART RATE CONTROL MODE (CL-108HP ONLY) provides a wireless heart rate monitoring system to help you control the intensity of the workout.

To test display functions, press and hold the “ON/OFF” function on the key pad. The alpha-numeric panel should read all zeros (22 digit LCD). Release “ON/OFF” for display to clear.

STANDARD MODE

1. STEPPING ON

(See *photo A*) Support yourself by holding the stationary hand rails. Always step on the lower pedal first, applying enough weight to bring it to its lowest position. While still holding onto the stationary hand rails, step up onto the other pedal and bring the pedals to an even or level position.



Photo A. Step onto the pedal with enough weight to bring it to its lowest position.



Photo B. Select a hand position at approximately shoulder height.

2. Select a hand position at approximately shoulder height (See Photo B). Adjust the hand grips if necessary by unscrewing both handles. Unscrew the handles by turning the bottom of the handle toward you while you are standing on the machine. Reposition both handles by screwing them in with the rotation of the bottom of the handles going away from you. Tighten so that the handles are secure.
3. Turn the computer "ON" or "OFF" by pressing "**ON/OFF**" on the key pad. A tone will sound as the computer turns "ON" and when the machine turns "OFF".
4. The computer will automatically be in the STANDARD MODE indicated by "STD" shown on the display.
5. To count calories, press "**DISPLAY TOTAL CALORIES**" in the lower left of the key-pad. A tone will sound. You may use this function any time before or after starting exercise. On CL-108HP models, the "**DISPLAY TOTAL CALORIES**" function is located in the upper right hand corner of the key pad.
6. The computer will ask you to "**ENTER WEIGHT**" in pounds. Enter your weight by pressing the numbers on the key pad. A tone will sound each time a value is entered. Weights from 70-300lbs. can be selected. Press "**ENTER**" If the weight value is too low, or too high the computer will tone 4 times and the display will read "*value too low*" or "*value too high*". Re-enter a weight that is in the weight range.
7. Press "**START EXERCISE**" located in the upper right corner of the blue key pad. (The "**START EXERCISE**" function on the CL-108HP model is located on the lower left corner of the blue key pad.) A tone will sound as the "**START EXERCISE**" button is pressed. Begin Climbing or begin by stepping only (with hands holding the hand rails).



Photo C. Begin climbing or stepping by taking a short 4-6 inch step.

START SLOWLY!

Take a shallow 4-6 inch step height.
(The average step height of a flight of stairs is only 7 inches)

Beginner or intermediate climbers,
SHOULD NOT
TAKE A FULL 20 INCH STEP.
This step height is used by Advanced users.

**PICK A PACE YOU CAN MAINTAIN FOR
A MINIMUM OF 15 MINUTES.**

8. The following is an example of the CL-108H "STANDARD" readout: (On the CL-108HP, models, the "HEART RATE" function in the upper middle window of the display has replaced the "CALORIES BURN RATE" function)

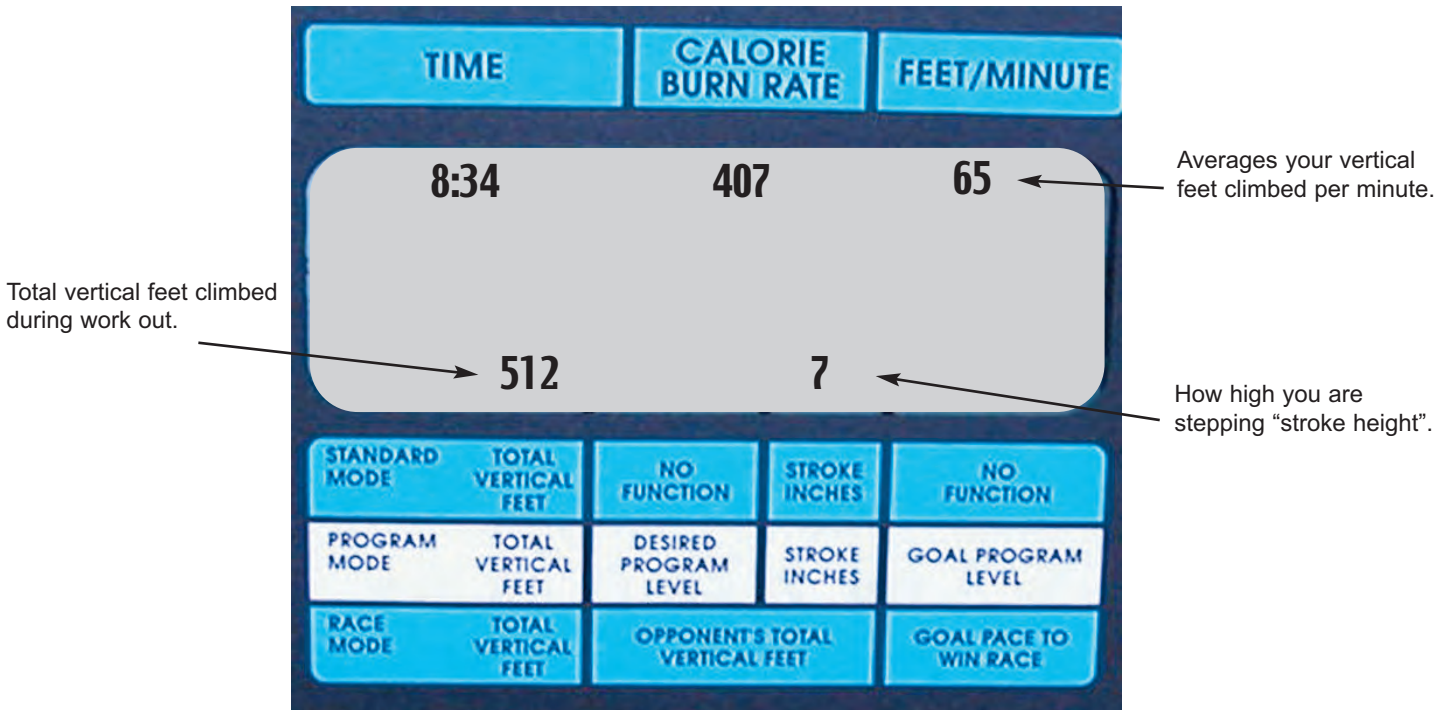

WARNING:
To maintain a shock and trauma free motion, do not under any circumstances hit the foot pedals on the limit stops on the bottom of the machine.

9. Your calorie burn rate is displayed in the upper middle digits. The rate is dependent upon weight entered and the rate at which you are climbing. (For CL-108HP model only, the middle upper "CALORIE BURN RATE" readout has been replaced with "HEART RATE"). It is based in per hour figures and will display from 1 to 999 calories burned. For calorie burn rates over 1,000, only the last three digits will be displayed. For example, if you are burning 1,123 calories per hour, your calorie burn rate will be displayed at 123.

10. To get an average of your stroke length and feet per minute, press "DISPLAY AVERAGES". A tone will sound as these values are flashed on the lower window of the display. "DISPLAY AVERAGES" may be viewed in any mode and will appear for 2 seconds and then return to the previous values displayed.

11. TO CHANGE MODES DURING A WORKOUT, YOU MUST FIRST STOP CLIMBING OR STEPPING FOR A FEW SECONDS. Then select another mode and enter the appropriate data.

12. Record your total vertical distance climbed or stepped and total exercise time to use as a goal for your next workout. See VersaClimber *Exercise Log* example, Page 3

13. If you should forget to turn the machine off, or if you stop exercising for two minutes, one tone will sound and the computer will automatically shut off. All data will be cleared from the display.

14. If the proper “key in” sequence causes the computer to “lock” or “freeze” and data cannot be entered or changed, remove the battery from the back of the module momentarily. Put the battery back in the module and continue.

***Note:** If you should make an error while entering data, press “CLEAR” and the latest numbers entered into the system will be erased. Re-enter correct data and continue.*

PROGRAM MODE

1. To choose a program level that is appropriate for your fitness, you must first workout in the “STANDARD” mode to determine an average speed (feet per minute) that is comfortable. If you press “**DISPLAY TOTAL AVERAGES**” after your work out, an average of your total feet per minute will be displayed. When first selecting a program level, your average feet per minute should be used as a guideline. You may find that the program you have chosen is too easy or too difficult and therefore you must select your program level accordingly.

Example:

If your average feet per minute, at the end of a workout, in the “STANDARD” mode was 60, your program selection would be #7 on the Program Level Chart on page 18. By looking in the AVERAGE column, 60 is closest to the figure 62 feet per minute. Follow that number to the top of the chart to find the program level, which in this example is #7. After a program level has been selected, the computer will ask you for the length of time you wish to workout. A gradual warm up will be included in each program.

5. Press “**ENTER PERSONAL INFO**”. A tone will sound.

6. The display will ask you to enter “**LENGTH OF TIME**” in minutes you wish to workout. Enter minutes by pressing large numbers on the key pad. A tone will sound each time a number is selected. If you wish to workout for 30 minutes simply enter **3** and **0** and press “**ENTER**”. You may enter a workout time from 1 to 99:00 minutes into the

computer. After completing a workout for more than 99:00 minutes (1hour and 39 minutes) you must turn the machine off and then back on and then reprogram the computer for additional minutes.

7. The display will ask you to enter a “PROGRAM LEVEL” from 1 to 16. A tone will sound as the program level is selected. Choose a pre-programmed workout level that is appropriate for your level of fitness. See PROGRAM LEVEL CHART page 18. Press “ENTER”. If a value entered is too high, the computer will tone four times and the display will read “value too high”.

8. Press “START EXERCISE” located in the upper right corner of the blue key pad. (The “START EXERCISE” function on the CL-108HP model is located in the lower left of the keypad.) A tone will sound as “START EXERCISE” is pressed.

9. Below is an example of the CL-108H “PROGRAM” readout: (On the CL- 108HP model, the “HEART RATE” function in the upper middle window of the display has replaced the “CALORIE BURN RATE” function).

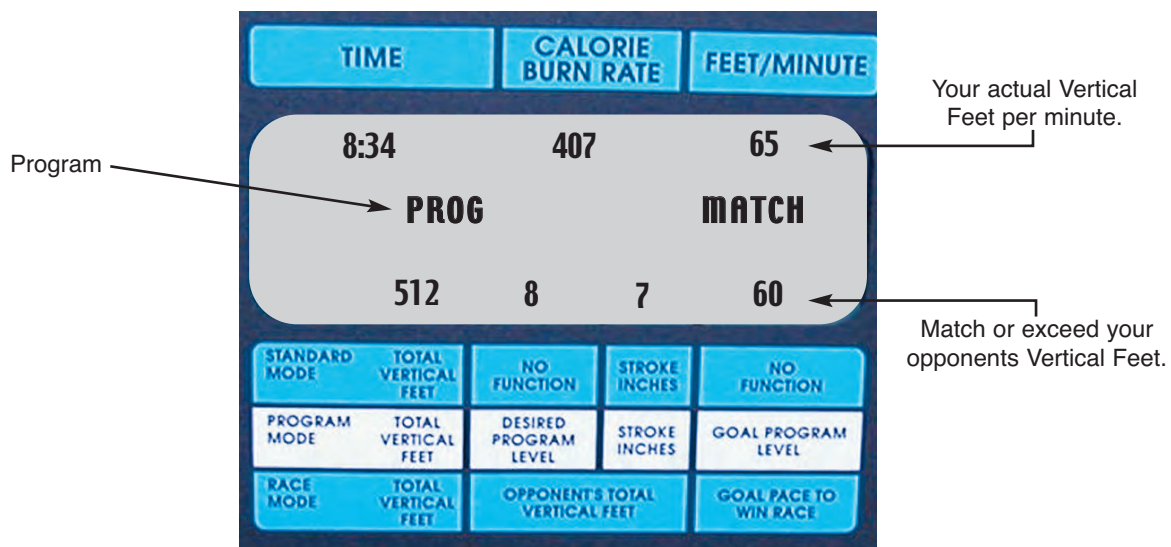

OBJECTIVE: Is to have your actual “FEET/MINUTE” displayed in the upper right hand corner match or exceed the “GOAL PROGRAM LEVEL” located directly below.

To Match or exceed your “OPPONENTS VERTICAL FEET” you can: increase your speed while maintaining a fixed stroke length or maintain a fixed speed while increasing your stroke length or increase your speed and your stroke length simultaneously.

DO NOT OVER EXERT YOURSELF! IMMEDIATELY DISCONTINUE THIS OR ANY OTHER EXERCISE IF YOU FEEL FAINT, DIZZY, SHORTNESS OF BREATH OR ANY OTHER PHYSICAL DISCOMFORT.

10. Your calorie burn rate is displayed in the upper middle digits. This rate is dependent upon weight entered and the rate at which you are climbing. (For CL-108HP models only, the middle upper “CALORIE BURN RATE” readout has been replaced with HEART RATE”) It is based on per hour figures and will display from 1 to 999 calories burned. For calorie burn rates over a 1,000 only the last three digits will be displayed. For example, if you are burning 1,123 calories per hour, your calorie burn rate will be displayed as 123.

11. To display total calories (optional), press “**DISPLAY TOTAL CALORIES**” located in the lower left of the display. The computer will ask you to “**ENTER WEIGHT**” in pounds. By pressing the large numbers on the key pad, your weight in the range of 70-350 lbs can be entered into the computer. Press “**ENTER**” If the weight entered is too low, or too high, the computer will tone four times and the display will read “*value too low*” or “*value too high*”. To obtain the total number of calories burned while you are working out, press “**DISPLAY TOTAL CALORIES**” again. Total calories, up to 999, will be momentarily displayed on the bottom of the display. The total calories burned will be displayed for 2 seconds and then revert to the previous values displayed.

12. To get an average of your stroke length and feet per minute press “**DISPLAY AVERAGES**”. A tone will sound as these values are flashed in the lower window of the display. “**DISPLAY AVERAGES**” may be viewed in any mode and will appear for 2 seconds and then return to the previous values displayed.

13. TO CHANGE MODES DURING A WORKOUT YOU MUST FIRST STOP CLIMBING OR STEPPING FOR A FEW SECONDS. Then select another mode and enter the appropriate data.

14. If you should forget to turn the machine off or if input information to the computer is interrupted for two minutes, one tone will sound and the computer will automatically shut off. All data will be cleared from display.

15. If proper “key in” sequence causes the computer to “lock” or “freeze” and data cannot be entered or changed, remove the battery from the back of the module momentarily. Put the battery back into the module and continue.

NOTE: *If you should make an error while entering data, press “clear” and the last numbers entered into the system will be erased. Re-Enter correct data and continue.*

RACE MODE

1. Press "**ON/OFF**" to turn computer "ON" or "OFF". A tone will sound when the computer turns "ON" and when the computer turns "OFF".
2. Press "**RACE MODE**". A tone will sound as the mode is selected. "RACE" will appear in the middle of the display to indicate "RACE MODE". *(On CL-108HP Models, press "**CHANGE MODE**" until "RACE" appears in the middle of the display to indicate "RACE MODE".) A tone will sound each time "CHANGE MODE" is selected.*
3. To count calories, press "**DISPLAY TOTAL CALORIES**" in the lower left corner of the blue keypad. A tone will sound once. You may use this function any time after starting exercise. *(On CL-108HP models, the "DISPLAY TOTAL CALORIES" function is located in the upper right hand corner of the keypad.)*
4. The computer will ask you to "ENTER WEIGHT" in pounds. Enter your weight by pressing the large numbers on the display. A tone will sound each time a value is entered on the keypad. Weights from 70 -- 350 lbs can be selected. Press "**ENTER**". If the weight value entered is too low, or too high, the computer will tone four times and the display will read "value too low" or "value too high".
5. Press "**ENTER PERSONAL INFO**". A tone will sound.
6. The display will ask you to enter "LENGTH OF TIME" in minutes you wish to work-out. Enter number of minutes by pressing numbers on key pad. A tone will sound each time a number is selected. For example, if you wish to workout for 30 minutes, simply enter **3** and **0** then press "**ENTER**". You may enter a workout time from 1 to 99:00 minutes in the computer. After completing a workout of more than 99:00 minutes (1 hour and 39 minutes) you must turn the machine "OFF" and then back "ON" and then reprogram the computer for additional minutes.
7. You are asked to enter the "TOTAL VERTICAL FEET" you wish to climb. A tone will sound each time a number is selected on the keypad. The range of display is 000 to 9,999 feet. A tone will sound as you press "**ENTER**".
8. Press "**START EXERCISE**" located in the upper right corner of the blue keypad. *(The "START EXERCISE" function on the CL-108HP models is located in the lower left*

corner of the keypad.) A tone will sound as “START EXERCISE” is pressed. Begin climbing immediately--as your opponent has begun to race!

9. The following is an example of a CL-108H “RACE” display readout: (The CL-108HP models have “HEART RATE” in place of the “CALORIE BURN RATE” function).

TIME		CALORIE BURN RATE		FEET/MINUTE	
8:34		407		65	
		RACE		MATCH	
512		510		7 65	
STANDARD MODE	TOTAL VERTICAL FEET	NO FUNCTION	STROKE INCHES	NO FUNCTION	
PROGRAM MODE	TOTAL VERTICAL FEET	DESIRED PROGRAM LEVEL	STROKE INCHES	GOAL PROGRAM LEVEL	
RACE MODE	TOTAL VERTICAL FEET	OPPONENT'S TOTAL VERTICAL FEET		GOAL PACE TO WIN RACE	

DO NOT OVER EXERT YOURSELF! IMMEDIATELY DISCONTINUE THIS OR ANY OTHER EXERCISE IF YOU FEEL FAINT, DIZZY, SHORTNESS OF BREATH OR ANY OTHER PHYSICAL DISCOMFORT.

OBJECTIVE is to have your “FEET PER MINUTE” pace, match or exceed the “GOAL PACE TO WIN THE RACE”. By matching or exceeding the “GOAL PACE”, your “TOTAL VERTICAL FEET” should also equal or be greater than the “OPPONENTS TOTAL VERTICAL FEET”. To match or exceed your “OPPONENTS VERTICAL FEET” you can: increase your speed while maintaining a fixed stroke length or maintain a fixed speed while increasing your stroke length or increase your speed and your stroke length simultaneously.

10. Your calorie burn rate is displayed in the upper middle digits. This rate is dependent upon weight entered and the rate at which you are climbing. For CL-108HP models only, the middle upper “CALORIE BURN RATE” readout has been replaced with “HEART RATE”. It is based on per hour figures and will display from 1 to 999 calories burned. For calorie burn rates over 1,000 only the last three digits will be displayed. For example, if you are burning 1,123 calories per hour, your calorie burn rate will be displayed as 123.

11. To display total calories (optional), press “**DISPLAY TOTAL CALORIES**” located in the lower left of the keypad. The computer will ask you to “*ENTER WEIGHT*” in pounds. By pressing the large numbers on the keypad, your weight in the range of 70 - 350 lbs can be entered into the computer. If the weight entered is too low or too high, the computer will tone four times and the display will read “value too low” or “value too high”. Press “**ENTER**”. To obtain the total number of calories burned while you are working out, press “**DISPLAY TOTAL CALORIES**” again. Total calories, up to 999 will be momentarily displayed on the bottom line of the display. The total calories burned will be displayed for 2 seconds and then returned to the previous values selected.

12. To get an average of your stroke length and feet per minute, press “**DISPLAY AVERAGES**”. A tone will sound as these values are flashed in the lower window of the display. “*DISPLAY AVERAGES*” may be viewed in any mode and will appear for 2 seconds and then return to the previous values selected.

13. *TO CHANGE MODE DURING A WORKOUT YOU MUST FIRST STOP CLIMBING OR STEPPING FOR A FEW SECONDS.* Then select another mode and enter the appropriate data.

14. If you should forget to turn the machine off, or if input information to the computer is interrupted for two minutes, one tone will sound and the computer will automatically shut off. All data will be cleared from the display.

15. If improper “key in” sequence causes the computer to “lock” or “freeze” and data cannot be entered or changed, remove the battery from the back of the module momentarily. Put the battery back into the module and continue.

Program Level Chart

PROGRAM NUMBERS

1 2 3 4 5 6 7 8 9 10 11 12 13 14 15 16

FEET PER MINUTE CLIMB RATES

Minutes	10	15	20	25	30	35	40	45	55	75	95	115	135	155	175	195
0-1	15	20	25	30	35	40	45	50	60	80	100	120	140	160	180	200
1-2	20	25	30	35	40	45	50	55	70	90	110	130	150	170	190	210
2-3	25	30	35	40	45	50	55	60	80	100	120	140	160	180	200	220
3-4	30	35	40	45	50	55	60	65	85	105	125	145	165	185	205	225
4-5	25	30	35	40	45	50	55	60	80	100	120	140	160	180	200	220
5-6	30	35	40	45	50	55	60	65	90	110	130	150	170	190	210	230
6-7	35	40	45	50	55	60	65	70	100	120	140	160	180	200	220	240
7-8	25	30	35	40	45	50	55	60	85	105	125	145	165	185	205	225
8-9	30	35	40	45	50	55	60	65	90	110	130	150	170	190	210	230
9-10	35	40	45	50	55	60	65	70	100	120	140	160	180	200	220	240
10-11	40	45	50	55	60	65	70	75	110	130	150	170	190	210	230	250
11-12	30	35	40	45	50	55	60	65	105	125	145	165	185	205	225	245
12-13	35	40	45	50	55	60	65	70	110	130	150	170	190	210	230	250
13-14	45	50	55	60	65	70	75	80	100	120	140	160	180	200	220	240
14-15	30	35	40	45	50	55	60	65	90	110	130	150	170	190	210	230
15-16	35	40	45	50	55	60	65	70	100	120	140	160	180	200	220	240
16-17	40	45	50	55	60	65	70	75	110	130	150	170	190	210	230	250
17-18	35	40	45	50	55	60	65	70	100	120	140	160	180	200	220	240
18-19	30	35	40	45	50	55	60	65	105	125	145	165	185	205	225	245
19-20	35	40	45	50	55	60	65	70	100	120	140	160	180	200	220	240
20-21	40	45	50	55	60	65	70	75	110	130	150	170	190	210	230	250
21-22	30	35	40	45	50	55	60	65	105	125	145	165	185	205	225	245
22-23	35	40	45	50	55	60	65	70	110	130	150	170	190	210	230	250
23-24	45	50	55	60	65	70	75	80	100	120	140	160	180	200	220	240
24-25	30	35	40	45	50	55	60	65	90	110	130	150	170	190	210	230
25-26	35	40	45	50	55	60	65	70	100	120	140	160	180	200	220	240
26-27	40	45	50	55	60	65	70	75	110	130	150	170	190	210	230	250
27-28	35	40	45	50	55	60	65	70	100	120	140	160	180	200	220	240
28-29	30	35	40	45	50	55	60	65	105	125	145	165	185	205	225	245
29-30	35	40	45	50	55	60	65	70	100	120	140	160	180	200	220	240
30-31																

FEET

32 37 42 47

Beginner
AVERAGE FEET PER MINUTE

FEET

52 57 62 67

Average
AVERAGE FEET PER MINUTE

FEET

95 115 135 155

Advanced
AVERAGE FEET PER MINUTE

FEET

175 195 215 235

Elite
AVERAGE FEET PER MINUTE

Module Display CL-108 HP



HEART RATE MONITORING INSTRUCTIONS

A Polar compatible strap is included with the VersaClimber 108HP. Any other Polar Compatible Heart Beat Transmitter strap will function with Model No. CL-108HP.

Place the Transmitter on the chest just below the breast/pectoral muscles and adjust the strap so that it is held securely against skin. Moisten the skin and the electrodes on the transmitter, (ribbed area that goes against the body). If the monitor must be worn over clothing, select thin cotton material and thoroughly moisten the material under the electrodes.

The strap can be moved up or down, left or right, to find the best transmitting location for the body. The accuracy, reliability, battery life and warranty are the same as that of the manufacturer of the strap.

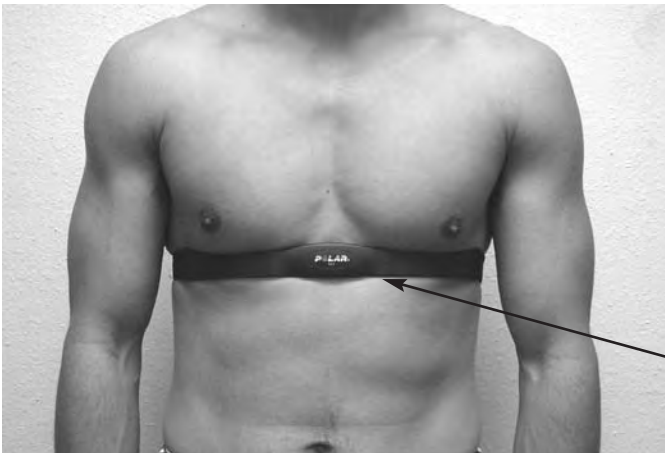

Heart Rate Chest Strap

HEART RATE CONTROL MODE

The HEART RATE CONTROL mode of the VersaClimber will guide you through a workout which slowly increases over 8 to 10 minutes until you reach and maintain your selected heart rate goal. This mode requires the use of the heart rate chest strap featured above. The chest strap is also required if you wish to read heart rate while in any of the STD, PROG or RACE modes. After selecting other modes, press **“READ HEART RATE”**.

1. Set up and wear the chest strap as previously described. Double check that the chest strap is functioning by stepping onto the Versaclimber, switching the display module to **“ON”**, and pressing **“READ HEART RATE”**. The heart beat symbol should flash and after a few beats, your heart rate should be displayed in the upper center window if the display.

2. Press the “**CHANGE MODE**” button until the letters “*HRC*” are visible in the display indicating “*HEART RATE CONTROL*” mode. A tone will sound each time the mode is changed. Modes can only be changed while the Versaclimber is stopped.

3. Press “**ENTER PERSONAL INFORMATION**”. The display will respond with “*ENTER AGE*”. Enter your age from 15 to 70 years with the numeric keys and press “**ENTER**”. A tone will sound each time the numeric keys and as “**ENTER**” is pressed. If the age entered is too low, or too high, the computer will tone four times and the display will read “value too low” or “value too high”.

4. After your maximum heart rate is entered, the computer will calculate and display your target value (80% of your maximum heart rate). To accept this value press “**ENTER**”. If you wish to exercise at some other heart rate, enter that value with the numeric keys and press “**ENTER**” Note: Only values within 20 beats of the computers calculated values will be accepted. A tone will sound each time the numeric keys and as “**ENTER**” is pressed. Beginners, and others who have been advised by their doctor, should select a training heart rate lower than 80% of their maximum training heart rate. Refer to the Training Heart Rate Chart on page 23.

5. After your target heart rate is entered, the computer will respond with “*ENTER TIME*”. Enter the number of minutes you wish to exercise by pressing the key pad and press “**ENTER**”. The first 8 to 10 minutes of the time you enter will be a warm up period. Thus, if you want to be at your target rate for 20 minutes, a workout time of approximately 30 minutes is recommended. A value of 0:00 to 99:99 minutes may be entered.

6. Press “**START EXERCISE**” to start the exercise program. If the chest strap is not functional the computer will tone three times and (*NO HR ///) will appear in the display. Moisten skin under the strap and or readjust the strap and press “**READHEART RATE**”. After a few moments, your heart rate will appear in the upper, center window. At the lower right of the display, a goal climbing speed in feet per minute will be displayed, your actual feet or “*FEET PER MINUTE*” will be displayed directly above the goal. Climb at a speed that causes these two numbers to match. The goal, based on your heart rate, will be updated every 30 seconds after a tone sounds.

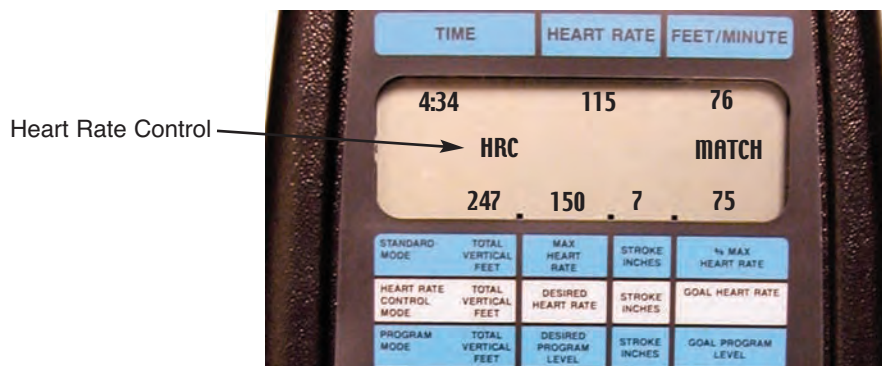

The CL-108HP example above shows a heart rate of 115 beats per minute after 4 minutes and 34 seconds of exercise. A total of 247 feet has been climbed at a current 7 inch step height. The goal heart rate is 150 beats per minute and the current climb rate is 76 feet /min. which is close to the goal of 75 feet per minute.

7. To display total calories (optional), Press “**DISPLAY CALORIES**” located in the upper right of the keypad. The computer will ask you to “*ENTER WEIGHT*” in pounds. By pressing the large numbers on the keypad, your weight in the range of 70 -- 350 lbs can be entered into the computer. If the weight entered is too “*low*”, or too “*high*”, the computer will tone four times and the display will read “value too low” or “value too high” press “**ENTER**”. To obtain the total number of calories burned while you are working out, press “**DISPLAY CALORIES**” again. Total calories up to 999 will be momentarily displayed on the bottom line of the display. The total calories burned will be displayed for 2 seconds and then revert to the previous values displayed.

8. To get an average of your stroke length and feet per minute press “**DISPLAY AVERAGES**”. A tone will sound as these values are flashed in the lower window of the display. “*DISPLAY AVERAGES*” may be viewed in any mode and will appear for 2 seconds and return to the previous values displayed.

9. *TO CHANGE MODES DURING A WORKOUT, YOU MUST FIRST STOP CLIMBING OR STEPPING FOR A FEW SECONDS.* Then select another mode and enter the appropriate data.

10. After your workout is complete, replay heart rate and feet per minute at one minute intervals by pressing “**INSTANT REPLAY**”.

11. If you should forget to turn the machine off, or if computer is interrupted for two minutes, one tone will sound and the computer will automatically shut off. All data will be cleared from the display.

12. If improper “key in” sequence causes the computer to “lock” or “freeze” and data cannot be entered or changed, remove the battery from the back of the module momentarily. Put the battery back into the module and continue.

NOTE: If you should make an error while entering data, press “**CLEAR**” and the last numbers entered into the system will be erased. Enter correct data and continue.

OXYGEN CONSUMPTION

$$\text{MLS/LB} = 0.1336 (\text{Feet Per Minute Climb Rate}) + 3.1219$$

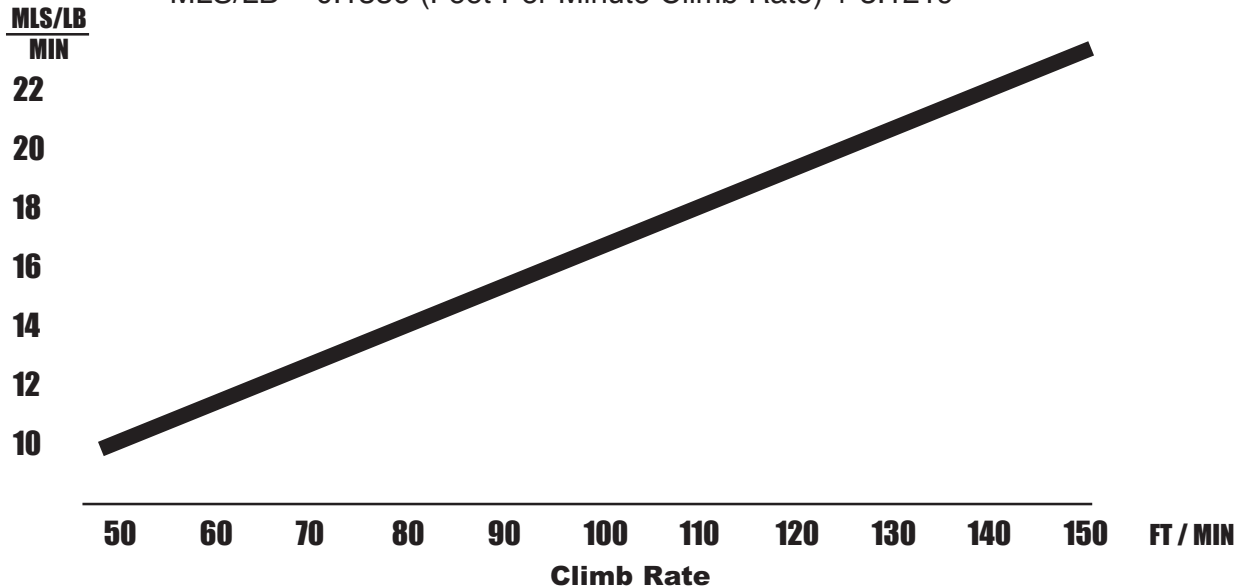

TRAINING HEART RATES

1. Find your age at the bottom of the chart.
2. Beginners follow the column to 70% of your maximum heart rate.
3. Advanced follow the column to 85% of your maximum heart rate.
4. Exercise at your appropriate heart rate.

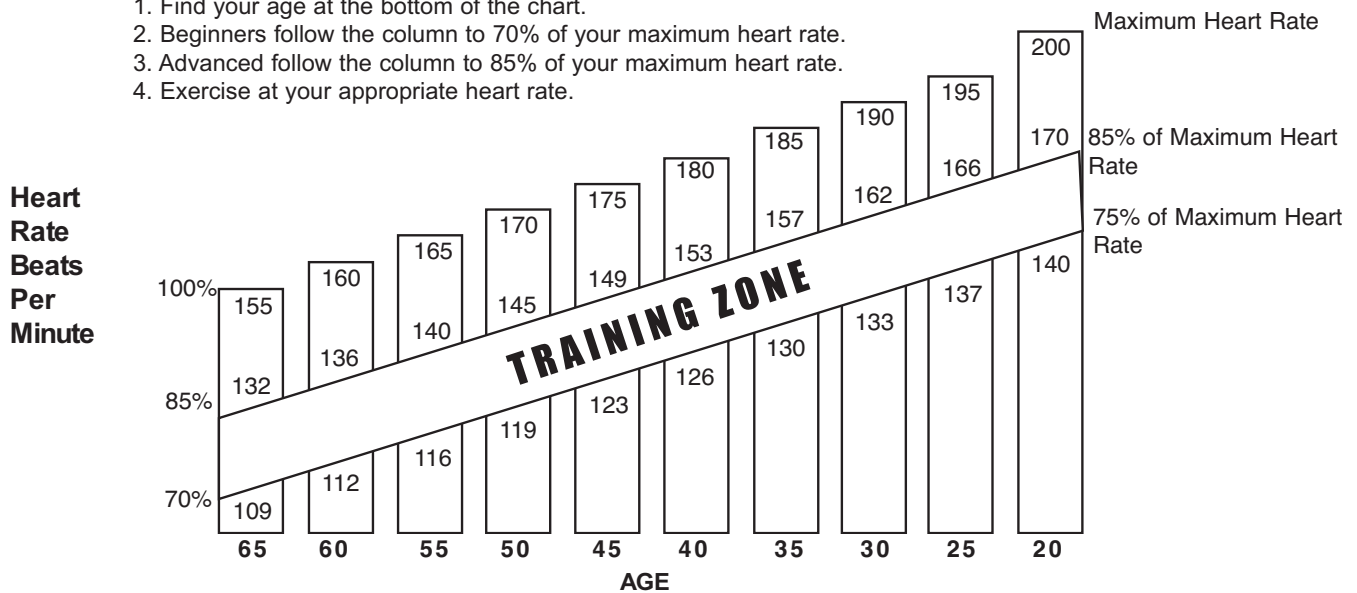

ACTIVITY	SPEED	CALORIES BURNED IN 30 MINUTES OF EXERCISE
Walking	3.0 mph	114
Bicycling	9.4 mph	192
Swimming	2.0 mph	243
Running	7.4 mph	396
VersaClimbing	1.3 mph (115 ft/min.)	420

VERSACLIMBER CALORIES BURNED PER HOUR CHART

	40	50	60	70	80	90	100	110	120	130	140	150	160	170
	FEET PER MINUTE													
80	205	238	270	303	335	368	400	432	465	497	530	562	595	627
90	231	267	304	340	377	414	450	487	523	560	596	633	669	706
100	257	297	338	378	419	459	500	541	581	622	662	703	743	784
120	308	357	405	454	503	551	600	649	697	746	795	844	893	942
130	334	386	439	492	545	597	650	703	756	808	861	914	966	1019
140	359	416	473	530	586	643	700	757	814	870	927	984	1041	1098
150	385	446	507	567	628	689	750	811	872	933	994	1054	1115	1176
160	411	475	540	605	670	735	800	865	930	995	1060	1125	1190	1255
170	436	505	574	643	712	781	850	919	988	1057	1126	1195	1264	1333
180	462	535	608	681	754	827	900	973	1046	1119	1192	1265	1338	1411
190	487	565	642	719	796	873	950	1027	1104	1181	1258	1336	1413	1491
200	513	594	675	757	838	919	1000	1081	1162	1244	1325	1406	1487	1491
210	539	624	709	794	880	965	1050	1135	1221	1306	1391	1476	1562	1647
220	564	654	743	832	922	1011	1100	1189	1279	1368	1457	1546	1636	1725
230	590	683	777	870	963	1057	1150	1243	1337	1430	1523	1617	1710	1803
240	616	713	811	908	1005	1103	1200	1297	1395	1492	1590	1687	1785	1882

Weight
in lbs.

1. Find your weight in the weight column
2. Find your climbing speed in feet per minute at the top of the chart
3. Read calories burned per hour in table

If your weight exceeds 240 pounds, divide your weight in half and follow the above 3 steps. Double the calories per hour figure to get your total calorie burn rate based on your climbing speed (feet per minute) and weight.

For most people losing weight it is often very difficult. It requires discipline in your eating habits as well as participating in a regular exercise program. The objective to losing weight is to consume less and exercise more, thereby expending calories that would normally be stored in the body as fat. For example, 3,500 calories equals 1 pound of fat. If you eat 3,500 calories in a single day and expend 1,750 calories as energy (including walking, exercising, breathing etc.) you would gain a 1/2 pound of fat. Over a one week period, by consuming 3,500 calories each day and converting only half the calories into energy, you would gain 3 1/2 pounds. Remember, to lose weight you need to decrease your calorie intake and increase your physical activity. Elite athletes often eat thousands of calories each day to maintain their body weight due to their high and frequent exercise activity.

STRENGTH EXERCISE DURING AEROBIC CONDITIONING

The following are strength exercises that can be performed during your aerobic workout. To strengthen specific muscles, you can step or climb in a variety of positions to concentrate the work on those specific areas. Guidelines for lower body strength workouts are outlined in the section “Working The Upper and Lower Body Separately”, next page.



Push and pull with your arms in the forward or reverse grip position to increase upper body workload.

Upper Body Strength Exercises

With your hands in the reverse position (palms facing towards you), the frontal muscles of the deltoids and biceps in addition to the large muscles of the back are strengthened. Concentrate on pulling down right, then left, with your latissimus dorsi (side of back), anterior deltoids (front of shoulders), and the biceps muscles of the arm. This flexion on one side of the body while extension on the other side of the body will tone and trim your sides, stomach, back, and back of arms. Both sets of muscle groups, front and back can also be worked simultaneously by changing grips from the reverse to the forward hand grip positions (palms facing away from you).

WORKING THE UPPER AND LOWER BODY SEPARATELY

The two stationary hand rails can be used to grasp and anchor the upper body while stepping with the legs only. By holding the hand rails in front of you or to the side of your body and stepping with the legs only, the buttocks, front and back of the thighs, calves and shins can achieve a complete lower body aerobic and strength exercise. Stair stepping is also an effective way for beginners to become familiar with the Versaclimber. After regular use, the user can graduate to full body climbing. Heart rate can be increased or decreased during this exercise by increasing or decreasing your stroke rate (how fast you are stepping) or by increasing or decreasing your stroke length. This stepping exercise can be performed in any mode of operation.

For the advanced athlete, a “quad burn” can be achieved by squatting down (while holding the stationary handgrips) so that the knees are at approximately a 90 degree angle. With the knees positioned on either side of the Versaclimber, start with short steps and gradually increase to the maximum comfortable stroke. **THE KNEES MUST STRADDLE THE MACHINE** and the arms must be bent to maintain the body weight within the base of the machine.



Lower body workout. Grasp the hand rails and step with the legs only.



For advanced athlete, a “quad burn” can be achieved by squatting down and allowing up to a full 20” step height.



The arms and shoulders can be exercised by standing on the base plate in front of the Versaclimber and driving the moveable hand grips. Palms can be in the forward or reverse grip. Pull down with one arm and resist with the other arm, or push and pull with one arm while resisting with the other arm. During this activity, a full range of cyclic rates and stroke lengths can be selected to exercise the upper body only. These isolated exercises can be performed as an interval exercise during your regular aerobic workout. See Interval Training on next page.

Upper Body Workout. Stand on the base plate and push/pull with the arms.



Photo C *To develop your calves, climb on your toes.*



Photo D *Upper leg work can be achieved by climbing with the heel of your foot forward on the pedal.*

Foot Positioning

The position of your foot on the pedals will allow you to focus the work on specific muscle groups. To concentrate the work in your ankles and calves, climb on your toes. See photo C. Quad work can be accentuated by climbing with the heel of your foot forward on the pedal. See photo D. The intensity of the work for the inner legs can be increased by pointing the toes inward. Turning the toes outward will work the outer legs. If tingling or numbness in the foot occurs, reposition the foot on the pedal (forward or back) until you are comfortable. Also check shoe laces and toe straps that may be too tight.

———— INTERVAL TRAINING ————

Interval training is a training method for the athlete who wants an advanced workout to increase their anaerobic fitness level. The purpose of interval training is to provide periods of very high intensity anaerobic activity, separated by periods of low intensity aerobic recovery. By continuously changing the climber speeds (workloads) during a training session, your heart rate will range between the high and low levels of your target heart rate zone, thus conditioning the body to high intensity workloads.

The Versaclimber involves exercising the entire body simultaneously and therefore you should workout for at least 6 to 8 weeks at an aerobic pace before attempting interval training. Once you are comfortable with an aerobic workout of at least 30 minutes long you can begin interval workouts.

Interval training on the Versaclimber is achieved by the repetition of sprinting, resting, and sprinting. By increasing the speed and the stroke length of each step, the cardiovascular system becomes accustomed to extremely strenuous exercise and recovery to a steady state. An example would be running a hill and then returning to the bottom, walking and breathing deeply. At first, the work intervals should consist of short sprints (3-5 seconds) followed by a long recovery period. To recover, a short 4-6 inch step height is taken at a greatly reduced climbing speed, while breathing deeply. The recovery period should last as long as it takes for your heart rate to return to its lowest target range. As you become better conditioned, the working interval time should be increased, while the recovery time between each work interval will become shorter and shorter. These achievements indicate an improvement in cardiovascular recovery conditioning.

Remember to always warm-up for a minimum of 10-15 minutes on the Versaclimber before beginning interval workouts. It is also very important to continue climbing during recovery periods and to gradual cool down 5-10 minutes after your workout.

EXAMPLE Interval Workout for 150 LBS., 25 Year Old Healthy Male, Using 65% of Maximum Heart Rate As Recovery Heart Rate. $220 - 25 = \text{MHR} \times 65\% = 127$

AGE Maximum Heart Rate

- 0 - 15 MIN** Warm up to heart rate of 127 beats per min. (bpm) minimum.

- 15 - 20 MIN** Perform 3-5 sec. sprints. Allow heart rate to return to 127 after every sprint.

- 20 - 25 MIN** Maintain heart rate of 127

- 25 - 30 MIN** Perform 3-5 second sprints. Allow heart rate to return to 127 after every sprint.

- 30 - 35 MIN** Cool down to heart rate of 127

———— VERSACLIMBING AND CHILDREN ————

CHILDREN ON THE VERSACLIMBER MUST BE SUPERVISED AT ALL TIMES DURING THEIR WORKOUT. THE VERSACLIMBER IS NOT A TOY. SERIOUS PERSONAL INJURY OR DAMAGE TO THE EQUIPMENT MAY OCCUR IF THE VERSACLIMBER IS NOT USED PROPERLY.

WARNING: UNDER NO CIRCUMSTANCES ARE TWO PEOPLE ALLOWED ON THE VERSACLIMBER AT THE SAME TIME!

Under proper adult supervision, children can quickly learn a full range of fun and challenging exercises on the VersaClimber. The vertically adjustable pedals allow children as tall as 3 feet 6 inches to easily see the display module, grasp the moving hand grips and/or stationary hand rails to perform a full body climbing or lower body stepping exercise. Children from the approximate age of ten through active adult years can walk, jog, run or sprint vertically by taking steps from 4" to 20". The intensity of the workout can also be regulated by increasing or decreasing the rate of the climb from the workload of a slow walk to an all out sprint. Body weights may vary from sixty to three hundred and fifty pounds. For foot pedal adjustment, See Versaclimber Assembly Instructions Page 32.

———— VERSACLIMBING AND THE MATURE ADULT ————

There exists large differences between the physical capabilities of older adults and it is important to always "listen to your body". If you feel dizzy, faint, chest pain, shortness of breath or any other physical discomfort, stop climbing immediately. Since older adults may suffer from one or more chronic diseases, or disabilities, the appropriate modifications should be applied to reduce the intensity of the exercise. An increase in the range of joint motion, flexibility, coordination, balance, strength and functional capacity can result with regular exercise program on the VersaClimber. It is recommended that older adults start off slowly, in the "STANDARD" mode **taking a 4 to 6 inch step** at a pace that is comfortable and easy. The "PROGRAM" mode provides 16 preprogrammed workout levels to follow and regulate your workouts. It is recommended that you learn and use the heart rate control option on the CL-108HP model VersaClimbers. Heart rate is the best indicator for workout intensity and older adults especially need to control and modify their workouts based on heart rate. It is also recommended that beginners should climb or step 3 times a week at a duration of approximately 15-20 minutes. The frequency, duration and intensity of your workouts can be increased gradually to 4 or 5 times per week, and up to 30 minutes, depending on the individual.

WARNING:

*It is imperative that you consult your physician
Before engaging in any exercise program.*

VERSACLIMBER AND THE OVERWEIGHT PERSON

The VersaClimber can be comfortably used by individuals who are considered overweight (over 30% body fat) without the impact trauma of aerobic dance and running exercises. Hip, knee, ankle, and back problems can be avoided by climbing on the VersaClimber because it provides a smooth, no pounding, safe exercise that is not traumatic to the joints. An exercise guideline for those who are overweight is a low intensity workout for 5-10 minutes at about 60% of your target heart rate. Gradually increase your target heart rate at a rate of 5% every 6 to 8 weeks until your maximal target heart rate is achieved. See "*TARGET HEART RATE CHART*" page 23. Start slow, and gradually increase the intensity and workout time only after you feel completely comfortable with the level you are at.

DO NOT OVER EXERT YOURSELF! IMMEDIATELY DISCONTINUE THIS OR ANY OTHER EXERCISE IF YOU FEEL FAINT, DIZZY, SHORTNESS OF BREATH OR ANY OTHER PHYSICAL DISCOMFORT.

These Exercise Guidelines have been prepared as a general information guide for using the VersaClimber. It is not a prescription for exercise. Always use prudent judgement when exercising on the VersaClimber. Or any other exercise equipment.

CAUTION:

DO NOT LEAN BACK OR STRAIGHTEN THE ARMS BECAUSE THE MACHINE MAY BECOME UNSTABLE AND TIP OVER.

———— GET MOTIVATED! ————

VersaClimbing can be enjoyed by all members of the family from children to mature adults. When used correctly, it is a safe, fun activity that people often get “hooked on”. The exhilarating feeling after this full body workout can actually make you look forward to your next workout, almost immediately!

Encouragement in the form of family competitions may be needed for fitness goals to be achieved. For example, you may want to do a weekly contest to see who can climb the farthest (total vertical feet), the longest (maximum minutes climbed), total calories burned, weight loss, etc. Using your VersaClimber regularly is the key to looking and feeling your best.

———— CAN YOU TOP THESE TOWERS ————

Washington Monument	Washington D.C.	555 feet
Space Needle	Seattle, Washington	600 feet
Tokyo Tower	Tokyo, Japan	820 feet
Centre Point Tower	Sydney, Australia	1,000 feet
Empire State Building	New York, New York	1,040 feet
Sears Tower	Chicago, Illinois	1,454 feet
Moscow Tower	Moscow, Russia	1,761 feet
CN Tower	Toronto, Canada	1,815 feet

Record the time it takes to climb these towers and work towards climbing them faster. When you can climb these towers with ease, Tackle these mountains! These mountainous goals may be achieved in stages by recording your distance each time you workout ie; Day 1, Day 2, Day 3,etc. Add your total distance to the previous days workout distance. Challenge the whole family by climbing to the top of mountains that you can identify the height of in your local area!

Mount Cook	New Zealand	12,353 feet
Mount Fuji	Japan	12,392 feet
Mount Kenya	Africa	17,063 feet
Mount Everest	Himalayas	29,039 feet

Compare your running time capabilities to your climbing capabilities. An example would be to run the length of a football field (300 feet) and record your time. Climb 300 feet and record the time. You will notice that you can run a specific distance 3 to 5 times faster than you can climb. Although your climbing speed may be reduced, using both arms and legs to climb vertically against gravity is more work intensive than exercising the arms only or legs only. Your total body, VersaClimber workout incorporates more major muscles, providing increased cardiovascular, toning and weight loss benefits.

———— VERSACLIMBER ASSEMBLY INSTRUCTIONS ————

IF YOU HAVE ANY QUESTIONS AFTER YOU HAVE THOROUGHLY READ THE ASSEMBLY INSTRUCTIONS, CALL 714-850-9716 EXT.226 AND ASK FOR SERVICE.

Your VersaClimber comes partially assembled. Please read these assembly instructions thoroughly before setting up your VersaClimber. Clear an area away from any objects that might restrict your motion while setting up. A FLAT, LEVEL, NON-SLIP SURFACE IS NECESSARY TO ENSURE ITS STABILITY. It is suggested, for safety reasons, that two able body persons assemble the machine.

TOOLS REQUIRED FOR ASSEMBLY

- (One) 3/16" hex key wrench (provided)
- (Two) 1/2" open end or socket wrench *
- (Two) 9/16" open end or socket wrench *
- (One) 3/4" open end wrench *

*Adjustable crescent wrenches can be used in place of open end wrenches.

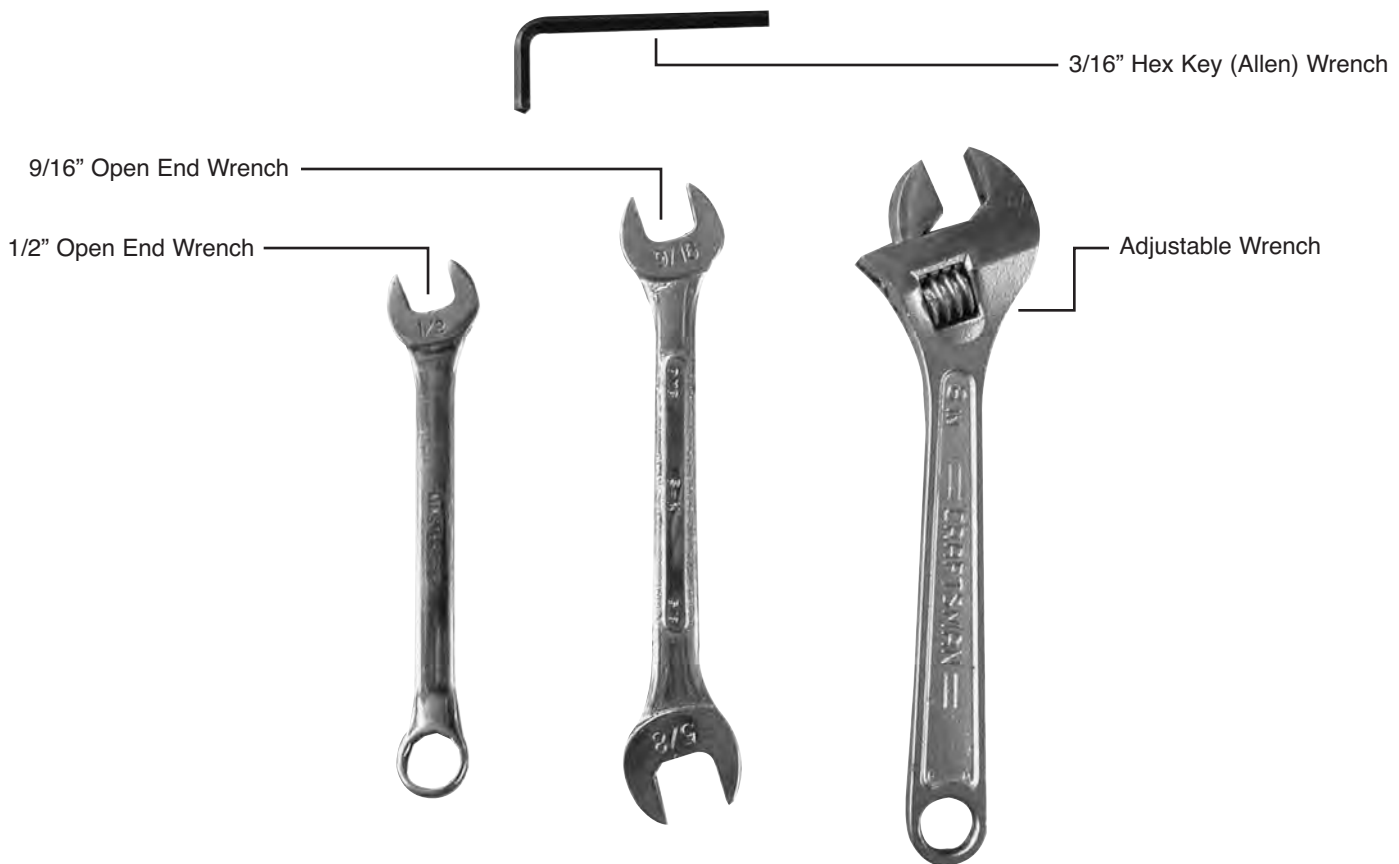



Lay the post on the floor with the large VersaClimber label facing up. Join base plate to post.

1. Assemble the base plate to the post. Using a 1/2" wrench, attach base plate (26) to post (2) as shown.

Use two flat head screws (25) and two lock nuts (23) found on the post. Tighten all nuts securely.



Attach base plate to post.

2. With the VersaClimber laying on the floor, tightly secure base plate to post.



Screw hand rails together.

3. Preassemble the left side and the right side hand rails. Each hand rail consists of one straight (13) and one curved section (11,12). By hand, screw the two straight hand rail sections into the two curved handrail sections and tighten securely.



Secure rails to base plate using 3/16" hex or Allen wrench.

4. Attach the straight section of the hand rail to the base plate (26), using the flat head screw; tighten with 3/16" hex wrench (provided).



Slip top of hand rail into post, Tighten bolt.

5. Attach assembled hand rail to the receiving end on the post. Tighten (bolt 47, nut 48) together.



Assemble brace and floor tie together.

6. Assemble the brace (16) to the floor tie (22) by screwing adjusting bolt into the brace. Screw the adjusting bolt in about halfway.



With another person holding at a slight angle, assemble the brace and tie to the post.



*Attach the tie with locknut to the bottom of the post.
Tighten securely.*

7. Assemble the brace (16) and tie (22) to the post (7) as shown here. This requires two people. Hold the post upright so that the base plate (26) is on the floor, then attach the top of the brace (16) with bolt (15) and locknut (14).

8. Attach the tie (22) with locknut (15) to the bottom of the post. Tighten securely.

9. Position the machine on a solid flat surface. *Do not place the machine on a plastic sheet, throw rug or anything that may cause the machine to slip when in use.*

10. When you select a location for your machine, be sure that there is enough space around the machine for free movement of your arms and legs.

Three holes have been machined into the moving foot pedal bar (35). This allows the foot pedals to be positioned at a higher level, providing both visibility to the display module and handle grips access for children as short as 3'6" tall. See VersaClimbing and Children page 29. The end of the left pedal shaft (20) is marked with an "L" and must go into the left side of the machine. All threaded holes on the left side of the machine are right handed threads.



Screw the foot pedal into one of the three foot pedal holes.

11. Screw the left & right pedal shaft into one of the three foot pedal holes. (**NOTE:** left side pedal tightens clockwise; right foot pedal tightens counter-clockwise) **TIGHTEN FOOT PEDAL SECURELY WITH 3/4" WRENCH.**



Screw right side hand grip counter clockwise to tighten.

12. Screw the left & right hand grips into upper shaft holes. (**NOTE:** left side grip tightens clockwise; right hand grip tightens counter-clockwise). Hand tighten grips.



13. Adjust screw (24) at the bottom of the angle brace (16) up or down until base plate lays flat on the surface on which it is placed. Then rotate the two levelers (54) located on the base plate to level the machine right to left. If the machine is placed on a deep pile carpet, it may be necessary to readjust the two leveling knobs after two or three days of use.



Rotate leveling knob up or down until base plate lays flat on the surface on which it is placed.

14. Be sure that all assembly steps have been accurately and thoroughly completed. Be extra careful to ensure that all the nuts are tight and that the foot pedals and hand rails are securely in place.

Note: There are three handle and foot pedal locations. For adults, screw the foot pedals into the lower holes and the hand grips into the holes that locate the hand grips at about shoulder height. The foot pedal can also be raised to a higher hole locations for shorter adults or children. Be sure to tighten the foot pedals securely with a wrench every time that they are installed.

15. Insert the display control connector on end of coil cord into the connector on the top of the post. The male connector on the coiled cord has a guide rib that must line up with the female connector on the machine prior to insertion.



Place the display console (Module) on the machine in contact with the velcro strips.



While standing on the pedals in the level position, the console (Module) should be at about eye level.

———— **BATTERY** ————

A nine volt alkaline battery that have been provided for the CL-108H & HP models are non-rechargeable. It has a life expectancy of about 60 hours and can be purchased at any store that sells batteries. A nine volt “nicad” rechargeable battery can also be purchased. A rechargeable battery pack (recharger and battery) can be purchased from your local battery store or from Heart Rate, Inc. and is normally good for 300-400 recharges. A recharged battery has a life of about 20-30 hours.

If you are climbing and the computer indicates a “*LOW BATTERY*”, you have about 1/2 hour of battery time remaining. Your battery will need to be replaced or recharged before your next workout.

If improper “key in” sequence causes the computer to “lock” or “freeze” and data cannot be entered or changed, remove the battery from the back of the module momentarily. Put the battery back into the module and continue.

———— **ROUTINE MAINTENANCE** ————

(Please refer to exploded view on Pages 41,42,43 for specific part location.)

The VersaClimber consists of a main frame post (2) that is made of extruded aluminum. The post has two rectangular slots that run through the full length of the machine. The post is supported by a base plate (26) and brace (16) and floor tie (22) that provide support for the machine. Two hand rails (11,12,13) also connect the post to the base plate.

The post (2) has a pulley (5) at the top and a spring loaded pulley (40) at the bottom. Two hand grips (10) and (10a) and two foot pedals (18) are part of the carriages (29) and (38) attached to aircraft cable (36) and (39) that goes around the two pulleys. The carriages (29) and (38) move up and down inside the post. The two hand grips and two foot pedals are screwed into the carriages. The carriages also have special molydisulfide filled nylon rollers (30) and slide bearings (32) to provide a smooth motion for the carriage. The slide bearings (32) are spring loaded (33) against the machine to cause an optimum preset climbing resistance.

The calorie burn rate, climbing speed, step length, and total distance climbed are calculated by monitoring the motion of the pulley (5) located at the top of the machine. An encoder disc (4), attached to the pulley rotated between two optical encoders that are on the cover (2). The clockwise and counter clockwise rotation of the encoder disc

provides input to the computer display console (9) and (9A). The computer is held on the machine by Velcro strips (8) and electronically connected to the cover (2) with a flexible coiled wire.

The routine maintenance of the VersaClimber is very simple. You can extend the life of the machine, maintain its appearance and smooth climbing motion by following these few easy steps.

————— **CLEANLINESS** —————

People that exercise on the VersaClimber will perspire. After every exercise session, wipe all surfaces clean with a damp cloth. Perspiration has a high salt content and is corrosive. Routine cleaning will prevent the painted surfaces from rusting or corroding.

————— **LUBRICATION** —————

There are 4 slide and roller bearing units that slide up and down inside of the vertical post structure to which the handgrips and foot pedals are attached.

The slides (image below) and the inner post surfaces are lubricated at the factory. When the lubricant on the inner surfaces of the post accumulates dust and/or dries out, a thick tar like substance can form that causes the machine to feel STICKY which may increase the resistance to slide freely. When this occurs the machine can be made to run like brand new by cleaning the inner tracks.

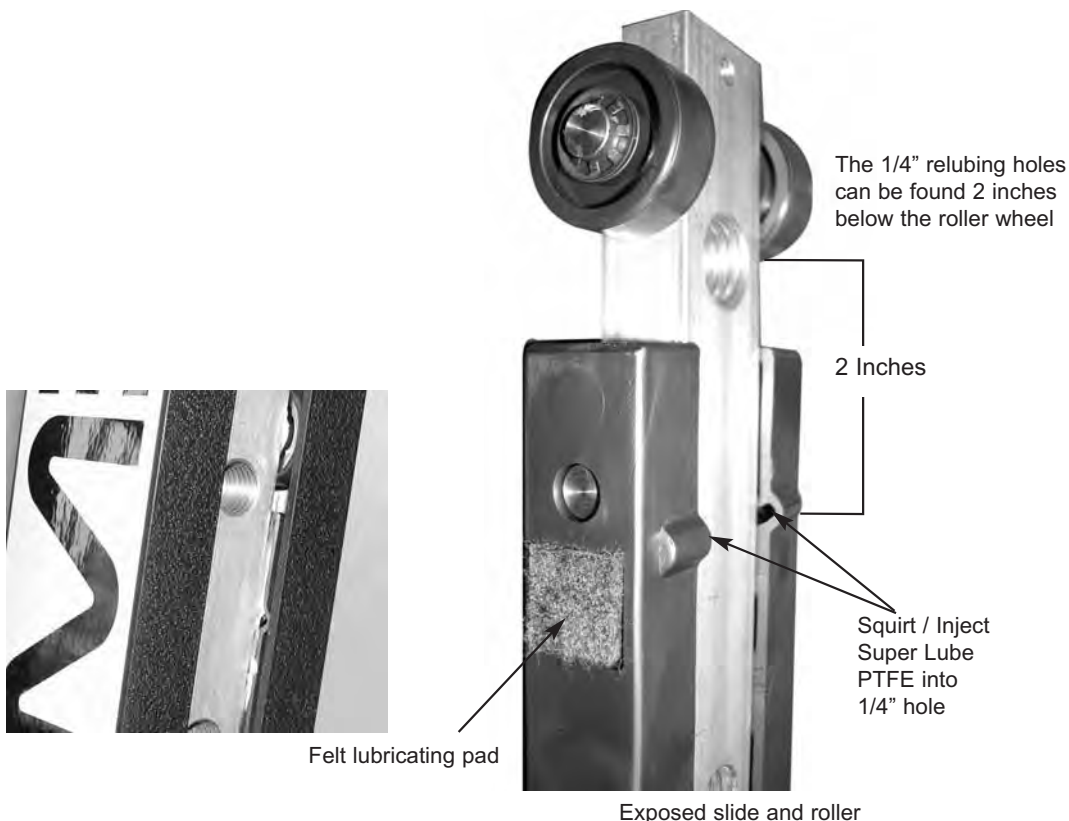



When resistance seems to have increased or movement begins to feel “sticky”, wipe all upper and lower inner surfaces with paint thinner to remove dry gummy lubricant build up.

If machine feels “sticky” or resistance increases use paint thinner in a spray bottle or on a rag to remove the thick lubricant from the inner-tracks. Wipe all upper and lower inner surfaces with paint thinner to remove dry lubricant. Move the machine through 20 -30 full cycles (pushing and pulling on the handles) and clean again. Then, after all dry sticky lubricant has been removed, be sure to wipe down with dry clean rag any paint thinner residue.

RELUBING

It's not necessary to relube after the first cleaning. if after the second cleaning, or at any time thereafter, the slide surfaces become completely dry, relube with 3-In-One High Performance Spray Lubricant with PTFE.

Note: *Do not use petroleum based products such as motor oil for relubing.*

Super Lube should be available at your local hardware or auto parts store. If not call 800.253.LUBE or call 800.237.2271 to order it from Heart Rate Inc.

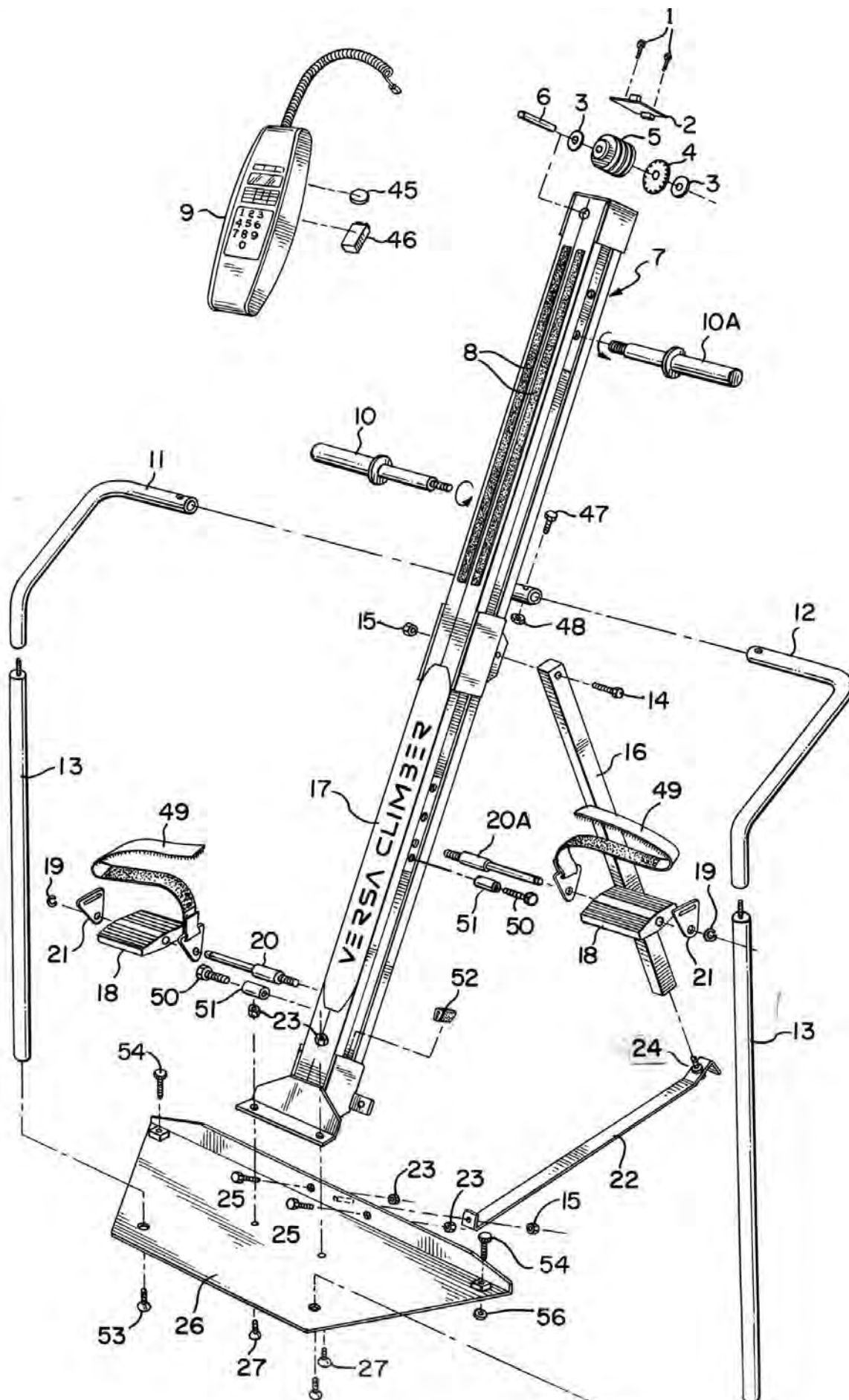

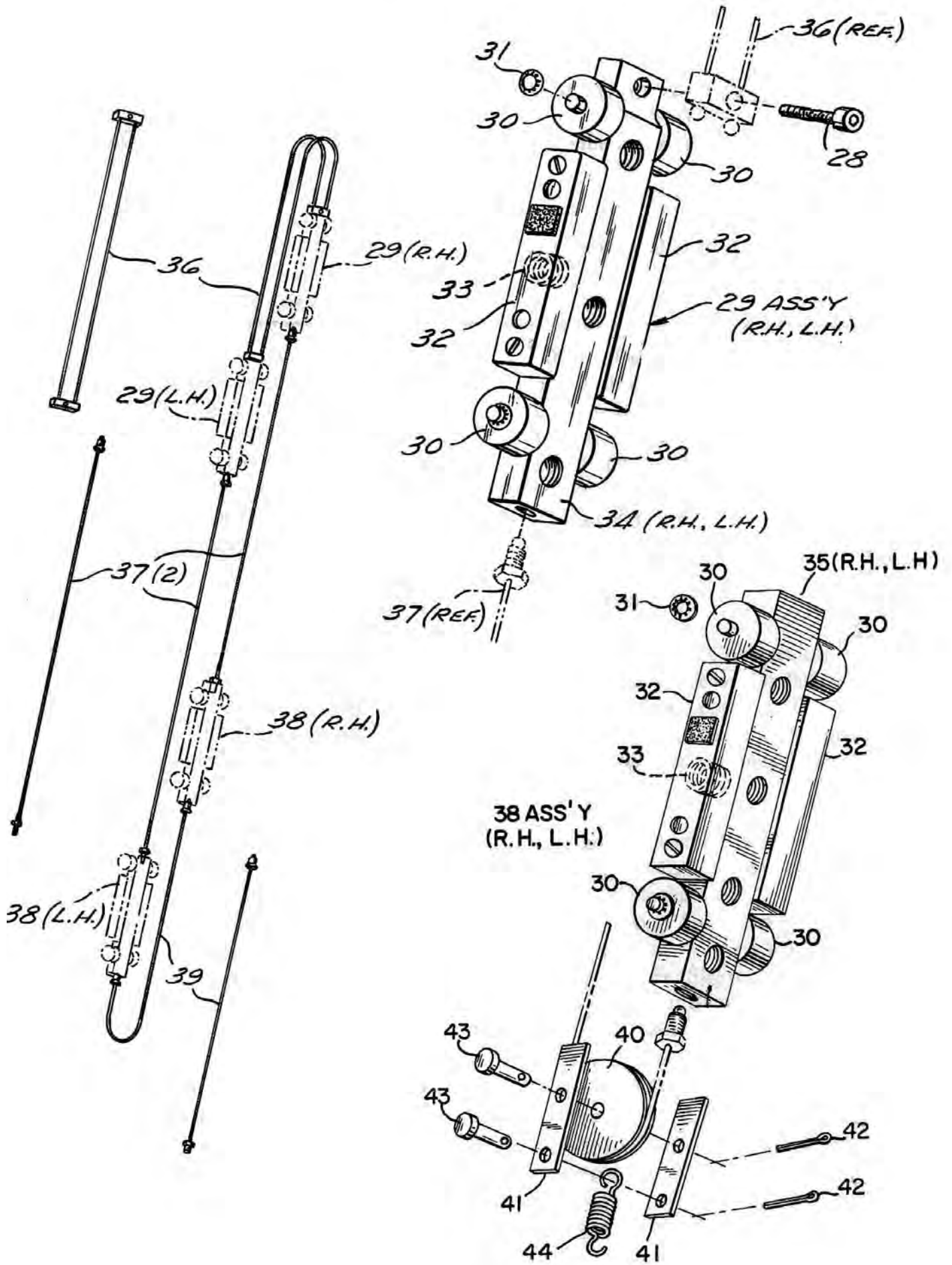

WARRANTY PARTS

Period starts from date on serial number.

FOR VERSACLIMBER MODEL CL-108H, CL-108HP

Warranty Parts Are Identified Per Item Numbers On Warranty Parts
Drawings (please refer to pages 41-43)

3 YEAR WARRANTY PARTS

<u>DRAWING NO.</u>	<u>ITEM NO</u>	<u>PART DESCRIPTION</u>
1	00089	Screw #6 - 32 x 3/8
3	00091	Washer, .375 OD. .065 thick
4	060-01-009	Encoder Disc
10 - Shaft	101-00-006	Handle Shaft L-side
10A - Shaft	101-00-007	Handle Shaft R-side
11	060-09-001	L-Hand Curved Rail
12	060-09-002	R-Hand Curved Rail
13	060-09-003	Straight Rail
14	00076	Screw, 3/8 - 16 x 1 3/4
15	00039	Nut, 3/8 -16 Lock
16	060-01-002	Brace Assembly
19	00031	Snap Ring
22	060-01-003	Tie Assembly
23	00081	Nut, 5/16 - 18 Lock
24	00001	Nut, 3/8 - 16 Lock
24A	00083	Bolt, 3/8 -16 x 2 1/2
25	00078	Screw, Hex Head 5/16 - 18 x 3/4
26	060-21-002	Base Plate Assembly
27	00079	Screw, FL. HD. 5/16 - 18 x 3/4
28	00111	Soc. HD Screw, 1/4 - 20 x 7/8
31	00008	Retaining Ring
33	00082	Spring
34	060-28-001	R.H. Top Bar
34A	060-29-001	L.H. Top Bar
35	060-30-002	R.H. Bottom Bar
35A	060-31-002	L.H. Bottom Bar
41	060-27-001	Clevis
42	00072	Cotter Pin
43	00071	Clevis Pin
47	00099	Screw, HX. HD. 5/16 - 18 x 1 3/4 Blk. Zinc
48	00081	Nut, 5/16 - 18 Lock Blk. Zinc
50	00097	Screw, FL. HD. Soc 5/16 - 18 x 1 1/2
54	00105	Knob, Base Plate Leveler
55	00106	Pad, Baseplate Leveler

2 YEAR WARRANTY PARTS

<u>ITEM NO</u>	<u>PART NO.</u>	<u>PART DESCRIPTION</u>
6	060-01006	Shaft, Pulley
7 - 108 Models	060-22-000	Post
7A - 1075 Models	065-04-000	Post
17	060-21-005	Label, Consumer (Blue)
18	060-04-002	Pedal
20	060-05-001	Pedal Shaft, Left
20A	060-04-001	Pedal Shaft, Right
30	003-00-005	Roller
32	003-00-009	Slide
37 -108 Models	060-25-000	Intermediary Cable Assembly
37A - 1075 Models	065-05-001	Intermediary Cable Assembly
39	060-26-000	Bottom Cable Assembly
40	00070	Pulley, Bottom
44	00073	Spring

1 YEAR WARRANTY PARTS

<u>DRAWING NO.</u>	<u>PART NO.</u>	<u>PART DESCRIPTION</u>
2	062-02-000	Encoder PCB Assembly
5	060-21-001	Triple Sheave Top Pulley
8	060-21-003	Velcro, Loop 1" x 30"
9 - H Module	061-02-000	Module Assembly, Regular
9A - HP Module	064-01-000	Module Assembly, Heart Rate
10 - Grip	30009	Grip
10A - Grip	30009	Grip
21	008-00-007	Connector, Pedal Strap
36	060-24-000	Top Cable Assembly
45	061-00-001	Velcro Disc
49	008-03-000	Single Foot Strap
50	00108	Screw, 1/2 - 13 x 1 1/2
51	00171	Rubber Sleeve
52	00173	Rubber Bumper
	109-04-002	Transmitter (only)
66	109-04-002	Elastic Strap (only)
	109-04-001	Heart Rate Monitor Strap

VERSACLIMBER 108H & 108HP THREE YEAR LIMITED WARRANTY

1. Heart Rate, Inc. (H.R.I.) warrants to the original purchaser that Institutional VersaClimbers are free from defects in material and workmanship under normal use and maintenance under a three year limited warranty subject to the terms and conditions Hereafter set forth. Except for the above warranty, it is expressly agreed that NO WARRANTY OF MERCHANTABILITY OR FITNESS FOR A PARTICULAR PURPOSE or of a particular use nor any warranty of any kind whatsoever express, implied or statutory is made by Heart Rate Inc.(HRI)
2. This warranty does not cover any damage caused by misuse, tampering, negligence, accidents, abnormal conditions, lack of adequate maintenance or unauthorized service or alterations to the product.
3. Liability of H.R.I. is limited to either repair or replacement of the defective part or the replacement of the machine at the option of H.R.I. on an exchange basis, with the customer bearing all costs of shipping and handling to and from the factory.
4. Length of Warranty, Parts

<u>ITEM</u>	<u>PARTS REPLACEMENT</u>
FRAME, HAND RAILS, BASE PLATE	3 YEARS
HANDLES	3 YEARS
FOOT PEDALS	2 YEARS
ROLLERS AND SLIDES	2 YEARS
DISPLAY ELECTRONICS	1 YEAR
ELECTRONICS	1 YEAR
HAND GRIPS	1 YEAR
FOOT PEDAL STRAPS	1 YEAR

5. During the first year, all labor is covered by the warranty. All labor repairs will be performed at the factory on warranty and non-warranty parts.
6. This warranty does not cover paint deterioration, discoloration, chipping or rust.
7. After all of the foregoing conditions have been complied with, if H.R.I. shall thereupon attempt repairs and /or replacements which shall for any reason fail, H.R.I.'s shall be allowed to continue to attempt to remedy any defects for so long a period of time as, In H.R.I. sole judgement, such attempt is justified.
8. The foregoing shall be buyer's sole and exclusive remedy, whether based on or otherwise, and H.R.I. shall not be liable for any injuries to persons or property. In no event shall H.R.I. be liable for incidental or consequential damages to commercial losses, nor for any other loss or damages except as above set forth.
9. This warranty is expressly in lieu of all other warranties, express or implied, and of all other obligations or liability on the part of H.R.I. No person, firm or corporation is authorized to assume any other liability on behalf of H.R.I.

VERSACLIMBER WARRANTY VALIDATION FORM
(MODEL CL-108H and CL-108HP)

To validate your Warranty Registration, please fill out the following form and return it to Heart Rate, Inc.

VersaClimber Model Number: _____

Machine Serial Number: _____

Name: _____

Address: _____

City: _____ State: _____ Zip: _____

Phone Number: (_____) _____

Email: _____ Fax: (_____) _____

Purchase Date: _____ From HRI [] Dealer [] Other []

Dealer Name : _____

Dealer Address: _____

City _____ State _____ Zip _____

I first saw/heard about the VersaClimber? _____

Friends who may be interested in owning a VersaClimber:

Name: _____

Address: _____

City _____ State _____ Zip _____

Phone: _____

Name: _____

Address: _____

City _____ State _____ Zip _____

Phone: _____



A trusted name in fitness for nearly 30 years. Proudly made in USA since 1981.

To learn more about other great VersaClimber accessories and options to enhance your workout, please visit us on line at www.versaclimber.com or call our toll free number at 1.800.237.2271 for more details.

